



Duty cycle	30 % (basis time 300 s)
Mode of operation	S3
Supply voltage	24 VDC ± 15 %
Nominal current	4.8 A
Positioning accuracy	± 1°
Positioning range	32 000 rotations not subject to mechanical limits
Shock resistance in accordance with IEC/DIN EN 60068-2-27	10 g 30 ms
Vibration resistance in accordance with IEC/DIN EN 60068-2-6	10 .. 150 Hz 10 g
Insulation class	B (120°)
Maximum axial force	axial shaft: 150 N radial shaft: 165 N
Maximum radial force	axial shaft: 200 N radial shaft: 440 N
Ambient temperature	max. 45 °C
Storage temperature	-25 .. 75 °C
Protection class	IP65
Weight	axial 2.8 kg/radial 3.2 kg
Certificates	CE/UKCA + NRTL

Product	Nominal torque	Self-holding torque	Nominal rated speed
HDA 70	15 Nm	25 Nm	27 min ⁻¹

Order code	A	B	C	D
HDA70				

Bus communication	A
EtherCAT	EC
PROFINET	PN
EtherNet/IP	EI
RS 485	I

Shaft position	B
axial, without bevel gear	L
radial, with bevel gear i = 1, position type 1	1
radial, with bevel gear i = 1, position type 2	2
radial, with bevel gear i = 1, position type 3	3
radial, with bevel gear i = 1, position type 4	4

Connections	C
Connector, 6-pin (RS485 without Hub)	E
Cable gland for 24 VDC, 2 x M12 female connector for IE-bus in/out	S
Male connector (7/8") for 24 VDC, 2 x M12 female connector for IE-bus in/out	T

Output shaft design	D
10 mm solid shaft with feather key (radial/axial)	S
10 mm hollow shaft (only radial, with bevel gear)	H10
12 mm hollow shaft (only radial, with bevel gear)	H12

HDA 70 with adapter
(axial, without bevel gear)

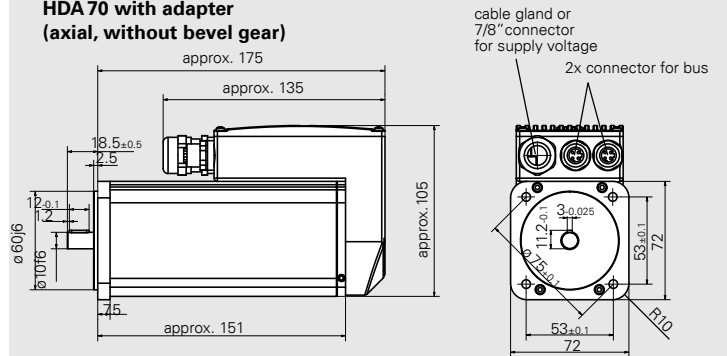

HDA 70 with adapter (radial, with bevel gear, i = 1)

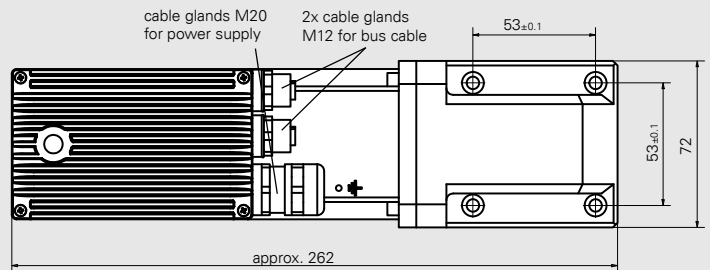
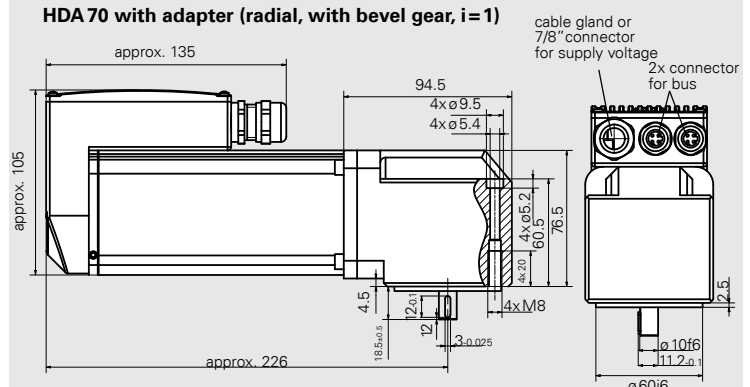

Shaft position

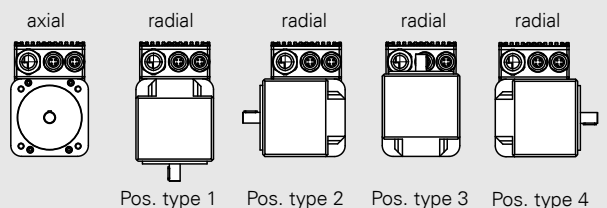

Accessories for HIPERDRIVE HDA70

HDA70 with bus communication (Industrial Ethernet ¹⁾)				
Industrial Ethernet ¹⁾	Bus cable for Industrial Ethernet with an M12 connector (D-cod.) 10 m: Order no. 9508.0045 20 m: Order no. 9508.0046		Power supply cable with a 7/8" connector socket 10 m: Order no. 9508.0043 20 m: Order no. 9508.0044	
	Connector set for EtherCAT, PROFINET, EtherNet/IP: 7/8" power supply connector + 2 x databus connector Order no. 9508.0050			

¹⁾ EtherCAT, PROFINET, EtherNet/IP

HIPERDRIVE HDA70 with bevel gear



You can order the bevel gear using the ordering key in option B.

The drawing with dimensions and the orientation of the shaft position is shown on the left.