

Instruction manual
PSD4xx positioning system



halstrup-walcher GmbH
Stegener Straße 10
79199 Kirchzarten
Germany

Tel. +49 7661 39 63-0
info@halstrup-walcher.com
www.halstrup-walcher.com

© 2023, Be

The manufacturer owns the copyright to this instruction manual. It contains technical data, instructions and drawings detailing the device's features and how to use them. It must not be copied either wholly or in part or made available to third parties.

The instruction manual is part of the product. Please read this manual carefully, follow our instructions, and pay special attention to the safety information provided. This instruction manual should be available at all times. Please contact the manufacturer if you do not understand any part of the instructions.

The manufacturer reserves the right to continue developing this device model without documenting such development in each individual case. The manufacturer will be happy to determine whether this manual is up-to-date.

Table of contents

1	Safety precautions	4
1.1	Appropriate use	4
1.2	Assembly, electrical connections and start-up	4
1.3	Troubleshooting, maintenance, repairs	5
1.4	Symbols	5
1.5	Storage and transportation	5
1.6	Disposal	5
1.7	Purpose of this user information	6
2	Description of the device and its functions	7
2.1	PSD4xx positioning system with bus interface	7
2.2	Examples of applications	7
2.3	Overview of features	8
2.4	Models and order key	9
2.5	Construction of devices with hollow shafts/gear reducers	10
2.6	Construction of devices with solid circular shafts	12
2.7	Type label	13
2.8	Device controls and status elements	14
2.8.1	Device controls and status elements CANopen / IO-Link	14
2.8.2	Device controls and status elements IE (Industrial Ethernet)	14
3	Installing the device	15
3.1	Installing drive with a hollow shaft	16
3.2	Installing drive with a solid circular shaft	18
3.3	Electrical connections and pin assignment	18
3.4	Grounding the housing	19
3.5	Dismantling	19
3.6	Powering the device	20
3.7	Duty cycle and mode of operation	20
3.8	Run drive in reverse	21
4	Communication interface	22
5	Technical data	22
6	Included in shipment	22
7	Notes	23

1 Safety precautions

1.1 Appropriate use

Positioning systems are especially suitable for automatically setting tools, stops or spindles for wood-processing equipment, packing lines, printing equipment, filling units and other types of special machines.

PSD4xx positioning systems are not stand-alone devices and may only be used if coupled to another machine.

Always observe the operating requirements – particularly the permissible supply voltage – indicated on the type label and in the “Technical data” section of this manual.

The drive may only be handled as indicated in this manual. Modifications to the device are prohibited. The manufacturer is not liable for damages caused by improper use or failure to follow these instructions. Violations of this type render all warranty claims null and void.

Never apply force to the housing cover, e. g. for supporting weight.

Provide sufficient ventilation in the mounting location to avoid excessive self-heating.

The drives are designed as appropriate use under normal conditions (according to EN / IEC / UL 61010- 1) except the extended ambient temperature range:

- Indoor use
- Altitudes up to 2,000 m
- Ambient temperature, deviating from standard: 0 C to 40 C;
- Maximum relative humidity of 80 % at temperatures up to 31 C, decreasing linearly to 50 % relative humidity at 40 C;
- Mains supply voltage fluctuations up to ± 10 % of the nominal voltage;
- The IP protection ratings are manufacturer's specification

1.2 Assembly, electrical connections and start-up

Assembly and the electrical connections should only be handled by professionals. They should be given proper training and be authorised by the operator of the facility.

The device may only be operated by appropriately trained individuals who have been authorised by the operator of the facility.

Specific safety precautions are given in individual sections of this manual.

The device must be installed by trained technical personnel.

1.3 Troubleshooting, maintenance, repairs

The individual responsible for the electrical connections must be notified immediately if the device is damaged or if errors occur.

This individual must take the device out of service until the error has been corrected and ensure that it cannot be used unintentionally.

This device requires no maintenance.

Only the manufacturer may perform repairs that require the housing to be opened.

1.4 Symbols

The device has been designed and tested to ensure its safety. However, it may still be dangerous if used inappropriately. Precautions must be taken to prevent the device being used incorrectly by mistake.

The following warnings are used in this instruction manual:



WARNING: This warns you of a potential hazard and possible consequences that could lead to serious bodily injury up to and including death if the corresponding instructions are not followed.



ATTENTION: This warns you of a situation where incorrect use could cause damage to the drive.



NOTE: This provides information about individual functions or special features.

1.5 Storage and transportation

The PSD4xx positioning system should always be stored and transported to the place of installation in its original packaging.

Information about storage and transportation can be found in the technical data sheet:

www.halstrup-walcher.de/en/products/drive-technology/direct-drives

Please search for "PSD", select your type, click on "Data sheets" and download the file.

1.6 Disposal

The electronic components of the device contain environmentally hazardous materials and materials that can be reused. The device must therefore be sent to a recycling plant when you no longer wish to use it. Compliance with the environmental codes of your country is essential.

1.7 Purpose of this user information

Some sections of this manual refer to external device-specific documents.

Requirement: An Internet connection is required.

The following additional documents are part of this instruction manual:

- Assembly instructions (general)
- Description of electrical connections and connectors (specific)
- Description of bus connections (specific)

Click the following link to find more technical information (such as data sheets, bus descriptions and manuals, function blocks or STP-files):

www.halstrup-walcher.de/technicaldocu

2 Description of the device and its functions

2.1 PSD4xx positioning system with bus interface



The PSD4xx positioning system is an integrated drive for the accurate adjustment of auxiliary and positioning axes. The drive enables the operator to perform reproducible and simultaneous adjustments at all the required positions. The PSD4xx positioning system converts a digital positioning signal into a rotational angle.

The integrated absolute measuring system eliminates the need for time-consuming reference runs. A bus system connection simplifies the wiring. A hollow shaft with an adjustable collar makes assembly quite simple.

The drive is especially suitable for automatically setting tools, stops or spindles for wood-processing equipment, packing lines, printing equipment, filling units and other types of special machines. The devices require no maintenance.

2.2 Examples of applications

- Wood-processing machines
- Packaging machines
- Food processing and beverages industry
- etc.

Format changeover in packaging machines

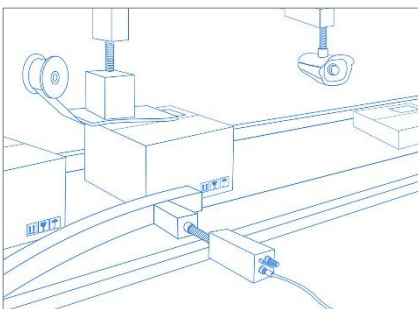

Format changeover in bottling plants

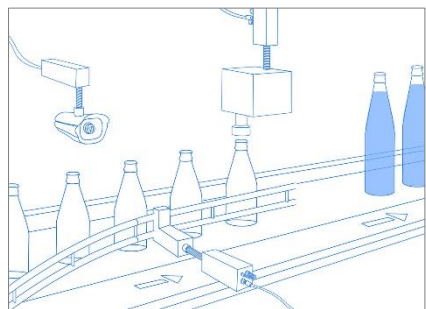

2.3 Overview of features

- Stepper motor
- Power amplifier and control electronics with galvanic separation (power and bus)
- Absolute measuring system (battery-free)
- Several bus interface options (see order key, chapter 2.4)
- 2 Protection class options (see order key chapter 2.4)
- Solid circular shaft (flattened), 5 mm or 8 mm
- Optional: Hollow shaft, 8 mm or 14 mm (with gear reducer)
- Optional: Gearbox kit for increased torque requirements with 8 mm or 14 mm hollow shaft
- Selectable connector orientation (horizontal or vertical with regard to the output shaft)
- Positioning runs:
 - o Positioning run with loop
 - o Positioning run without loop
 - o Manual run

2.4 Models and order key

The PSD4xx positioning systems can be adapted to specific requirements. The possible models can be configured using the order key:

Order code	A	B	C	D	E	F	G	H
PSD								
	A Type	B Torque/ Output shaft	C Rotation shaft/ Housing	D Bus communication ¹⁾	E Electical connections	F Protection class	G Software modules	H Certificates
	40: horizontal	1.5V 1-8H 1-14H with gearbox: 3-8H 3-14H	S: direct or 0° 1: 90° 2: 180° 3: 270°	CA: CANopen IO: IO-Link PN: PROFINET EC: EtherCAT EI: EtherNet/ IP	0: standard ²⁾	50: IP50 65: IP65 ³⁾	1: standard M: with modulo function ⁴⁾ S: with changeover of parameter set ⁴⁾ P: with target speed in process data ⁴⁾ Z: with modulo function and changeover of pa- rameter set and target speed in process data ⁴⁾	0: CE / UKCA N: NRTL + CE / UKCA
	41: vertical							
	42: horizontal	2-8V 2-8H 2-14H with gearbox: 4-14H 6-14H 8-14H						
	43: vertical							
	48: horizontal	0-5V 0-8H 0-14H with gearbox: 1-8H 1-14H						
	49: vertical							

B		C		C				
Key	Torque	Output shaft	Rotation shaft/Housing					
B1- B2	B1	B2	S	1	2	3		
direct	1-5V	1: 0.8 Nm	5V: 5 mm solid shaft		-	-	-	
	1-8H 1-14H	1: 0.8 Nm	8H: 8 mm hollow shaft 14H: 14 mm hollow shaft					
with gearbox	3-8H 3-14H	3: 3 Nm	8H: 8 mm hollow shaft 14H: 14 mm hollow shaft					
	direct	2-8V	2: 2 Nm	8V: 8 mm solid shaft		-	-	-
2-8H 2-14H		2: 2 Nm	8H: 8 mm hollow shaft 14H: 14 mm hollow shaft					
with gearbox	4-14H 6-14H 8-14H	4: 4 Nm 6: 6 Nm 8: 8 Nm	14H: 14 mm hollow shaft					
	direct	0-5V	0: 0.25 Nm	5V: 5 mm solid shaft		-	-	-
		0-8H 0-14H	0: 0.25 Nm	8H: 8 mm hollow shaft 14H: 14 mm hollow shaft				
with gearbox	1-8H 1-14H	1: 1 Nm	8H: 8 mm hollow shaft 14H: 14 mm hollow shaft					

- ¹⁾ others on request.
- ²⁾ standard equipment: 3 plugs / sockets with IO-Link; 1 plug
- ³⁾ IP 65 installed motor shaft IP 50
- ⁴⁾ only for IO-Link devices

2.5 Construction of devices with hollow shafts/gear reducers

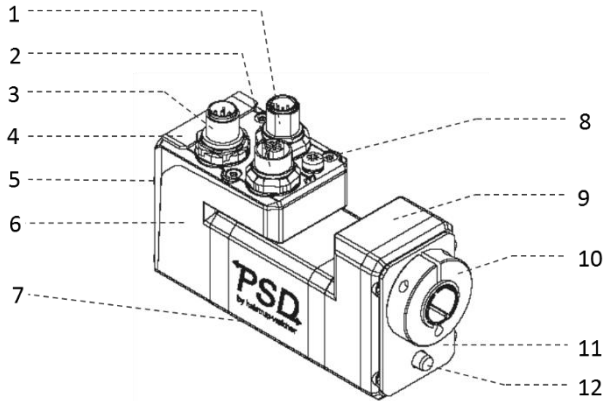

Illustration exemplary, here: PSD403-14H

- 1 M12 male connector for power supply (A-coded)
(for devices with IO-Link also for communication)
- 2 M12 connector for bus
CA: M12 female connector (B-coded)
EC/PN/EI: M12 female connector (D-coded)
not for IO (1 cable for power supply and communication signal)
- 3 M12 connector for bus
CA: M12 male connector (B-coded)
EC/PN/EI: M12 female connector (D-coded)
not for IO (1 cable for power supply and communication signal)
- 4 Sealing plug with
 - device controls (not for devices with IO Link)
 - status elements (see chapter 2.8)
- 5 Connection diagram: on the adjoining side of the connectors
(not for devices with IO-Link)
- 6 Housing section with power and control electronics
- 7 Type label (see chapter 2.7)
- 8 Grounding screw

9 Gearbox with hollow shaft:



Illustration exemplary (Models: see order code in chapter 2.4)

Attachment housing with hollow shaft:



Illustration exemplary (Models: see order code in chapter 2.4)

- 10** Hollow shaft, 8 mm or 14 mm,
with allen screw (M4 x 16 DIN 912) for spindle mounting
- 11** Damping plate (1.5 mm): to offset lash in the spindle
- 12** Torque support: Mechanical fixation to prevent the drive from twisting

2.6 Construction of devices with solid circular shafts

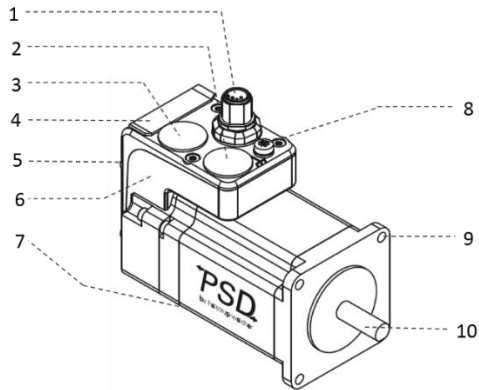
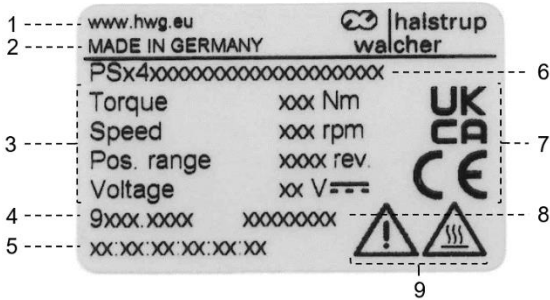

Illustration exemplary, here: PSD422-8V

- | | |
|-----------|---|
| 1 | M12 male connector (A-coded) (for device with IO Link for bus and power supply) |
| 2 | M12 connector for bus
CA: M12 female connector (B-coded)
EC/PN/EI: M12 female connector (D-coded)
not for IO (1 cable for power supply and communication signal) |
| 3 | M12 connector for bus
CA: M12 male connector (B-coded)
EC/PN/EI: M12 female connector (D-coded)
not for IO (1 cable for power supply and communication signal) |
| 4 | Sealing plug with <ul style="list-style-type: none"> - device controls (not for devices with IO Link) - status elements (see chapter 2.8) |
| 5 | Connection diagram: on the adjoining side of the connectors
(not for devices with IO-Link) |
| 6 | Housing section with power and control electronics |
| 7 | Type label (see chapter 2.7) |
| 8 | Grounding screw |
| 9 | Flange holes M3 (PSD40x/41x/48x/49x) or \varnothing 4.5 (PSD42x/43x) |
| 10 | Solid circular shaft (flattened), 5 mm or 8 mm |

2.7 Type label



- 1 Manufacturer and website
- 2 Country of manufacture
- 3 Technical data
- 4 Article number (specific)
- 5 MAC-address (only for devices with IE buses)
- 6 Order key
- 7 CE and UKCA conformity symbols
- 8 Serial number
- 9 Warning symbols:



observe installation and operating instructions



let the positioning system cool down sufficiently before touching

2.8 Device controls and status elements

There is a rectangular sealing plug on the side where the connector is located – the precise location depends on the selected orientation of the connectors. The device controls and status elements are located under the sealing plug.

2.8.1 Device controls and status elements CANopen / IO-Link

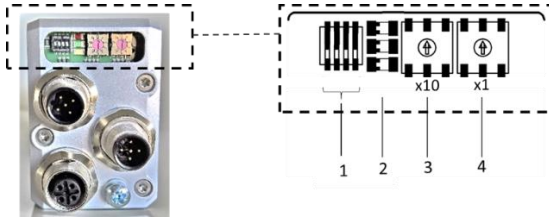

- 1 DIP-switches (left to right switches 1..4) (not present with IO Link)
- 2 Status LEDs (red and green LED = bus status; yellow LED = motor status)
- 3 Address switches x10 (not present with IO Link)
- 4 Address switches x1 (not present with IO Link)

2.8.2 Device controls and status elements IE (Industrial Ethernet)

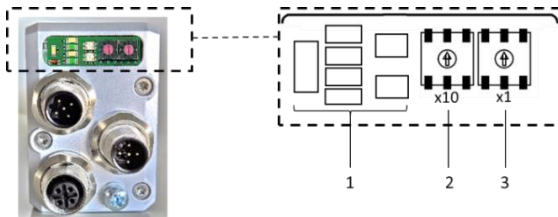









- 1 Status LEDs (bus status and motor status)
- 2 Address switches x10
- 3 Address switches x1

Click the following link to find more technical information about the control and status elements in the bus description: www.halstrup-walcher.de/technicaldocu

Please search for "PSD", select your type, click on "Instruction manuals" and download the files appropriate to your bus communication interface.

3 Installing the device

-  **WARNING** Risk of injury if used inappropriately.
The drive must be installed by trained technical personnel.
-  **WARNING** Risk of burns due to hot drive.
The drive can become very hot during operation.
Allow the drive to cool before touching it.
-  **WARNING** Risk of crushing due to rotary movement.
Do not reach into the working area of the drive when it is still turning.
The user/operator must ensure appropriate protective measures are taken.
-  **WARNING** Incorrect assembly can lead to the destruction of the drive.
-  **WARNING** Check that the supply lines are not pinched or crushed. They must not touch the housing of the drive or should be designed for the corresponding heat.
Lay the supply lines according to the general and specific local assembly regulations.
If the supply lines have not been delivered together with the drive, please select suitable cables for the application.
Do not operate the positioning system if the supply lines are noticeably damaged.
-  **WARNING** Risk of injury. High contact voltages can occur in the case of malfunctions.
This can be prevented by grounding.
-  **ATTENTION** The drive must be protected against excessive heating.
The user/operator must ensure appropriate protective measures are taken.
Ensure sufficient ventilation in the mounting location.
-  **ATTENTION** Never apply force to the housing of the drive, e. g. for supporting weight.
-  **ATTENTION** Submerged operation of the PSDs is not permitted.



Note: When the drive is running at certain speeds, depending on the application, resonances may occur which reduce its service life and increase noise. This can be avoided by changing the target rpm.

3.1 Installing drive with a hollow shaft

How to mount the drive with hollow shaft on a shaft

Requirements

Recommended shaft diameter	8 h9 or 14 h9
Depth of the hollow shaft bore	20 mm
Tightening torque of the adjustable collar screw with a 3 mm allen screw	4 Nm
Minimum depth of pin insertion into the hollow shaft bore	> 16 mm
Hole/long hole for torque support	6.05 .. 6.10 mm
Damping plate	Must be resting evenly or be pressed together at up to half thickness



ATTENTION: Depending on the operating situation, the use of significantly shorter pins (< 16 mm) may result in damage to the drive.

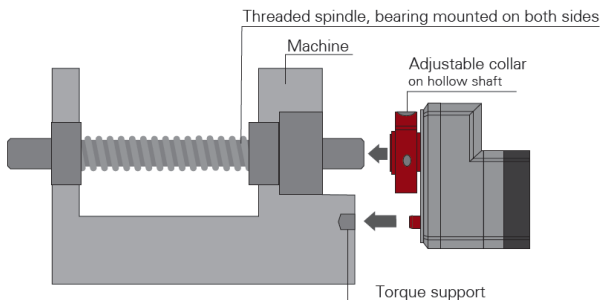

The depth of the hollow shaft bore is 20 mm. For optimum operation, the length of the pin of the shaft to be driven should correspond to this depth of the bore. Depending on the operating situation, the use of significantly shorter pins (< 16 mm) may result in damage to the PSD4xx.

When installing the PSD4xx, the device should only be pushed on until the damping plate on the base of the device is resting evenly on the machine, or being pressed together to approx. the half

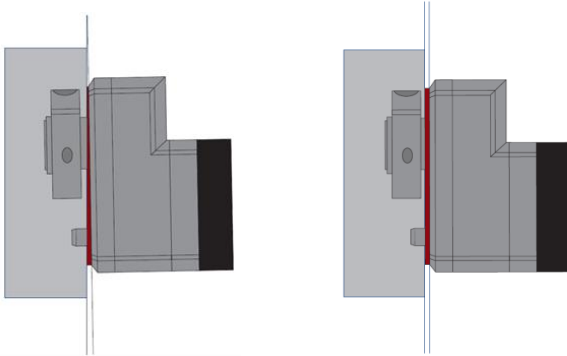

thickness. Under no circumstances must the PSD4xx be bolted on “hard” without an air gap between it and the machine.

- 
Note: When installing the device, ensure that the damping plate is parallel to the base of the device, see diagram:



INCORRECT ☹️

CORRECT 😊

- 
Note: The backlash that occurs when the direction of rotation changes has a direct influence on the positioning accuracy of the device. If the backlash is very high (several mm), the impact load may damage the drive.
- 
Note: When it has been mounted, there must be space around the drive on all sides. This is important because the drive can move axially and/or radially during positioning if the hollow shaft and solid shaft are not 100 % aligned. This “wobble” does not indicate a defect in the drive, nor does it impair the drive’s function as long as it can move freely.

3.2 Installing drive with a solid circular shaft

The drive with a solid circular shaft is installed on the axle to be driven using a coupling and an intermediate flange.

Install the drive according to the coupling manufacturer's specifications.

Requirements

Recommended internal diameter of hollow shaft of the coupling

5 H9 (PSD4xx-5V) or 8 H9 (PSD4xx-8V)

Stepper motor flange screws (not included, please select appropriate length)

Thread: M3 (PSD 40x/41x/48x/49x),
Borehole: Ø4,5 mm (PSD 42x/43x),
please use M4 screws and nuts, if applicable



Note: Install the drive according to the coupling manufacturer's specifications.

Example:

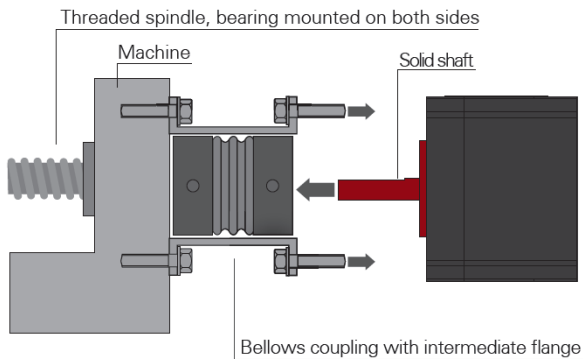

3.3 Electrical connections and pin assignment

Technical data for the electrical connections and pin assignment can be found in the pin assignment description on the website: www.halstrup-walcher.de/technicaldocu

Please search for "PSD", select your type, click on "Instruction manuals" and download the files appropriate to your bus communication interface, file name: Connector and pin assignments.

3.4 Grounding the housing

⚠ WARNING Risk of burns due to hot drive.
The drive can become very hot during operation.
Allow the drive to cool before touching it.

⚠ WARNING Risk of injury. High contact voltages can occur in the case of malfunctions.
This can be prevented by grounding.

Next to the connectors, there is an M4 screw for mounting the grounding cable.

! **Note:** The drive should be connected to the machine base using the shortest possible cable. The minimum wire cross-section of the grounding cable is 1.5 mm².

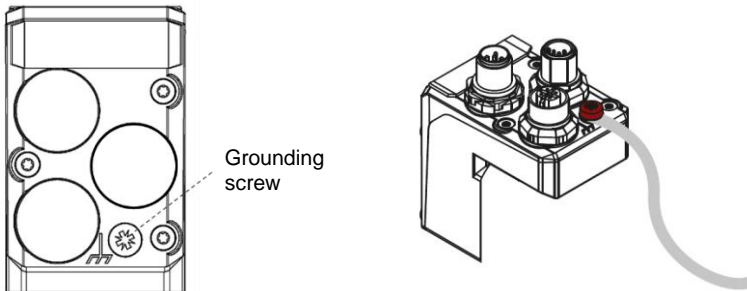

3.5 Dismantling

⚠ WARNING Risk of burns due to hot drive.
The drive can become very hot during operation.
Allow the drive to cool before touching it.

To dismantle, undo the clamp (the adjustable collar in models with a hollow shaft) and pull the PSD4xx off the shaft.

! **Note:** Ensure the drive is pulled off the shaft in the axial direction. Excessive bending can damage the output shaft.

! **Note:** When removing models with a solid circular shaft from a coupling, please follow the coupling manufacturer's instructions.

3.6 Powering the device

For the motor supply connection (SELV/PELV), it is required to provide adequate power limitation in compliance to e.g. IEC 61010-1, Limited Energy Circuit (LEC) or IEC 60950-1, Limited Power Supply (LPS).

To ensure this, the following fuse protection is recommended:

- For motor power use a single fuse with max. 4.0 A for each drive.
- For control power you can use a fuse with max. 2.0 A, so it is possible to power up to 10 units parallel with one fuse.
- The supply lines to the PSD4xx must be routed separately from other lines with dangerous voltage.

3.7 Duty cycle and mode of operation

The drives are designed for intermittent operation S3. When operating the drives under nominal power, the following duty cycle (DC) must be observed:

Device type	PSD40x/41x	PSD42x/43x	PSD48x/49x
Duty cycle [%]	up to 50 % DC S3	up to 30 % DC S3	up to 50 % DC S3

The mentioned duty cycles are guiding values. A higher duty cycle can be achieved by adjusting the parameters (speed, current).

Depending on the application, continuous operation S1 is possible with some variants. Please contact us if you have any questions.

3.8 Run drive in reverse

Depending on the model, the drive may be run in reverse up to a certain speed.



ATTENTION: Running a PSD4xx in reverse for more than 1-2 seconds at more than the permissible speed will damage the internal protection diode and the PSD4xx will be defective.

Please refer to the following table to find the maximum permissible speed:

Device type	PSD 401/411 - 5V/8H/ 14H	PSD 403/413 - 8H/14H	PSD 422/432 - 8V/8H/ 14H	PSD 424/434 - 14H	PSD 426/436 - 14H
Maximum permissible speed [rpm]	200	48	200	95	60

Device type	PSD 428/438 - 14H	PSD 480/490 - 5V/8H/ 14H	PSD 481/491 - 8H/14H
Maximum permissible speed [rpm]	45	200	48

4 Communication interface

Technical data for the communication interface can be found in the bus description on the website: www.halstrup-walcher.de/technicaldocu

Please search for "PSD", select your type, click on "Instruction manuals" and download the files appropriate to your bus communication interface.

5 Technical data

Technical data and drawings can be found in the current data sheet on the website: www.halstrup-walcher.de/en/products/drive-technology/direct-drives

Please search for "PSD", select your type, click on "Data sheets" and download the file.

Please contact us if you require any further information.

6 Included in shipment

The shipment includes the following:

- Assembly instruction
- PSD4xx positioning system

7 Notes

