



Original Operating Instructions

Differential Pressure Transmitter PS27



halstrup-walcher GmbH

Stegener Straße 10
D-79199 Kirchzarten
Germany

Phone: +49 (0) 76 61/39 63-0
Fax: +49 (0) 76 61/39 63-99

E-mail: info@halstrup-walcher.com
Internet: www.halstrup-walcher.com

Revision Overview

Version:	Date:	Author:	Amendments:
A	07/2010	Sie	Initial Revision
B	07/2011	Sie	Drawings capter 3.2, 3.3 and 6
C	07/2011	Sie	Dimensional drawing
D	02/2015	Sie	Specifications
E	10/2015	Sie	Additions in capter 4 and specifications
F	03/2017	Me	Additions
G	05/2017	Me	Accuracy, Certificate of Conformity
H	05/2018	Me	better differentiation between two and four-wire
I	03/2021	Me	Additions „Set Relay“
J	01/2022	Me	Revision overview; UKCA; M12-Plug; Certificate of Conformity
K	09/2022	RH	Measuring ranges changed
L	12/2022	Me	Update technical data, QR-Code
M	08/2024	Ts	New variant, connection, assembly, drawing, added

Translation of the original instructions

© 2024

The manufacturer owns the copyright to this instruction manual. It contains technical data, instructions and drawings detailing the device's features and how to use them. It must not be copied either wholly or in part or made available to third parties.

The instruction manual is part of the product. Please read this manual carefully, follow our instructions, and pay special attention to the safety information provided. This instruction manual should be available at all times. Please contact the manufacturer if you do not understand any part of the instructions.

Significance of the Operating Instructions

This instruction manual describes the function and handling of the PS27 differential pressure transmitter and provides guidelines for its use.

Every person who is tasked with carrying out work on or with the transmitter must have read and understood the operating instructions before starting work on it. This also applies if the person concerned has already worked with such a transmitter or a similar transmitter or has been trained by the manufacturer.

These appliances can pose a risk to persons and property due to improper use and incorrect operation. For this reason, every person entrusted with handling the appliances must be trained and aware of the dangers. The operating instruction and in particular the safety instruction contained therein must be carefully observed.

Always contact the manufacturer if you do not understand any parts of these instructions.

Handle these operating instructions with care:

- It must be kept within easy reach for the entire service life of the appliances.
- It must be passed on to subsequent personnel.
- Any supplements issued by the manufacturer must be included.

The manufacturer reserves the right to further develop this device type without documenting this in each individual case. Your manufacturer will be happy to provide you with information on the current status of these operating instructions.

Conformity

This pressure transmitter conforms with the present stage reached in technical engineering.

It complies with the statutory requirements of the EC and UK-directives.

This is documented by the CE and the UKCA mark being affixed.



Contents

- 1. Safety Instructions.....5**
 - 1.1 Use for Intended Purpose Only5
 - 1.2 Transport, Installation, Connection and Startup5
 - 1.3 Malfunctions, Maintenance, Repairs, Disposal.....5
 - 1.4 Symbols.....6
- 2. Description of the pressure transmitter6**
- 3. Startup6**
 - 3.1 Functional Description6
 - 3.2 Connections for Four-Wire version (standard) in the device:.....7
 - 3.3 Connections for Two-Wire System (Option):.....8
 - 3.4 Connections M12-plug8
- 4. Resetting Offset8**
- 5. Configuring the Output Signal.....9**
- 6. Setting the Measuring Range (Optional).....9**
- 7. Display (Option)10**
- 8. Setting the Relay Operating Point (Option).....10**
- 9. In case of Malfunctions10**
- 10. Specifications11**
- 11. Dimensional Drawing12**
- 12. Certificates of Conformity14**

1. Safety Instructions

1.1 Use for Intended Purpose Only

The PS27 differential pressure transmitter registers both differential pressure and positive/negative gauge pressure.

The operational requirements on the rating plate and in the "Specifications" chapter - and the safe supply voltage in particular - must be kept to.

The transmitter is only to be handled in conformity with these operating instructions. No modifications to the transmitter are permitted. The manufacturer is not liable for damage arising from any incorrect use or one at variance to the intended purpose. Claims to warranty in such an instance would be forfeited.

1.2 Transport, Installation, Connection and Startup

Do not block the pressure inlets on the transmitter being moved! Changes in barometric pressure may damage transmitters with low measuring ranges.

Only qualified personnel are to assemble the appliance and see to its electrical connections. They must be instructed as such and be assigned by the plant operator.

Only instructed persons as assigned by the plant operator are to operate the transmitter.

Do not perform any functional test involving compressed or breathable air. This would otherwise damage those transmitters with low measuring ranges.

Measurement errors may occur should the appliance not be protected from sunlight.

Specific safety instructions are given in the individual chapters.

1.3 Malfunctions, Maintenance, Repairs, Disposal

Malfunctions which cannot be put right as specified in Chapter 8 and damage at the appliance itself must be immediately reported to the qualified personnel with responsibility for the electrical connections.

The appliance must be taken out of service by the qualified personnel responsible until the malfunction has been put right and also secured against being unintentionally used.

Always switch off the power to the appliance before it is opened!

The appliance does not need any maintenance.

Only the manufacturer is to carry out repairs.

The electronic components of the instrument contain materials that can be reused. That is why the appliance is to be recycled once it is finally immobilized. The environment directives on this from the country in question must be followed.

1.4 Symbols

The symbols below in these operating instructions point to the risks, which could arise in handling the equipment:



WARNING!

It points to a hazard possibly extending from injures through to death should the instructions not be followed.



CAUTION!

It points to a hazard which could cause considerable damage should the instructions not be followed.



INFORMATION!

This indicates information, which is vital for proper appliance operations

2. Description of the pressure transmitter

Type PS27 differential pressure transmitters are pneumatic/electrical sensors for pressure testing (positive/negative gauge pressure and differential pressure) purposes. They are typically used in air-conditioning and ventilation technology e.g. pressure testing in ventilation ducts. The transmitter's core is a piezoresistive pressure transmitter.

3. Startup

3.1 Functional Description

PS27 pressure transmitters are of the precision type and despite their sturdiness they should still be treated with care. Installation right next to heat and radiation sources e.g. radiators should be avoided as this may lead to measurement errors arising. Ideally the appliance should be vertically mounted on a wall not subject to any vibrations. To stop any condensed water entering the measurement cell, the transmitter together with the hose connections for positive gauge pressure + and negative gauge pressure - should be pointing downwards.

The right pressure sign must be used in keeping with the following table when connecting the pressure to the transmitter:

Type of pressure	Connect pressure to	Example
pos. gauge pressure	+ input	0...1 kPa
neg. gauge pressure	- input	0...- 500 Pa
Differential pressure	Higher pressure at + input lower pressure at - input	0...125 Pa e.g via a differential pressure producer (e.g. measuring orifice)
Symmetrical pressure ranges	+ input	± 200 Pa

Asymmetrical pressure ranges	Input of the larger pressure range	-300 Pa...+ 1 kPa (here connect to + input)
------------------------------	------------------------------------	--

3.2 Connections for Four-Wire version (standard) in the device:

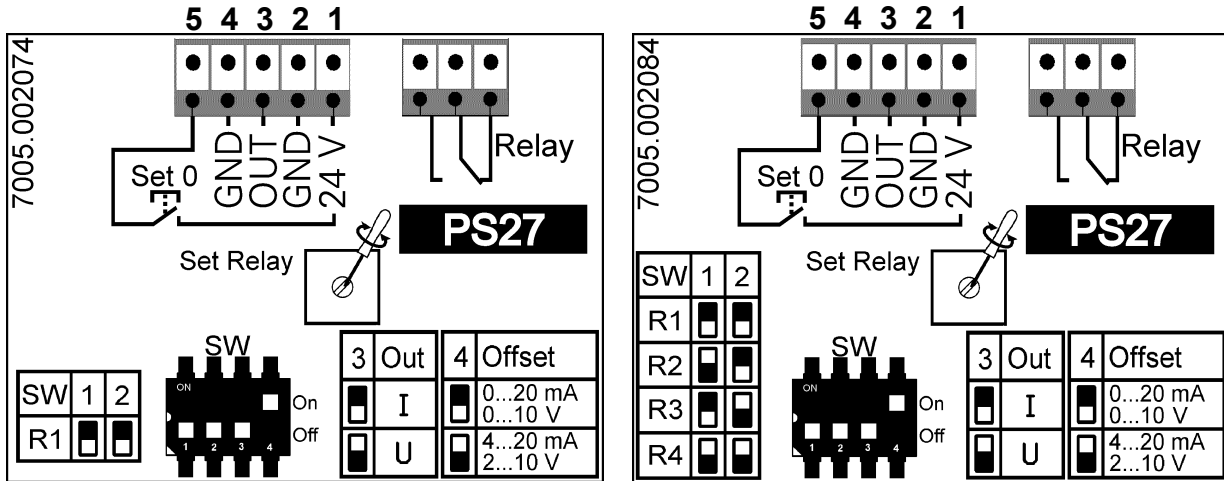

One measurement range

Four measurement ranges



Note the prescribed supply voltage (see rating plate). Also follow the connection diagram on the appliance cover / circuit board mount.

ST4 Pin	Connection name	Meaning
1	24V	Power supply input - 24VAC/DC
2	GND	Ground for power supply
3	OUT	Voltage or current output
4	GND	Ground for output signal
5	SET 0	Zero-point input (+24V zero-point is active)

The transmitter outputs are protected from short circuits. The DC-supplied appliances are protected from reverse polarity of the supply voltage.

3.3 Connections for Two-Wire System (Option):

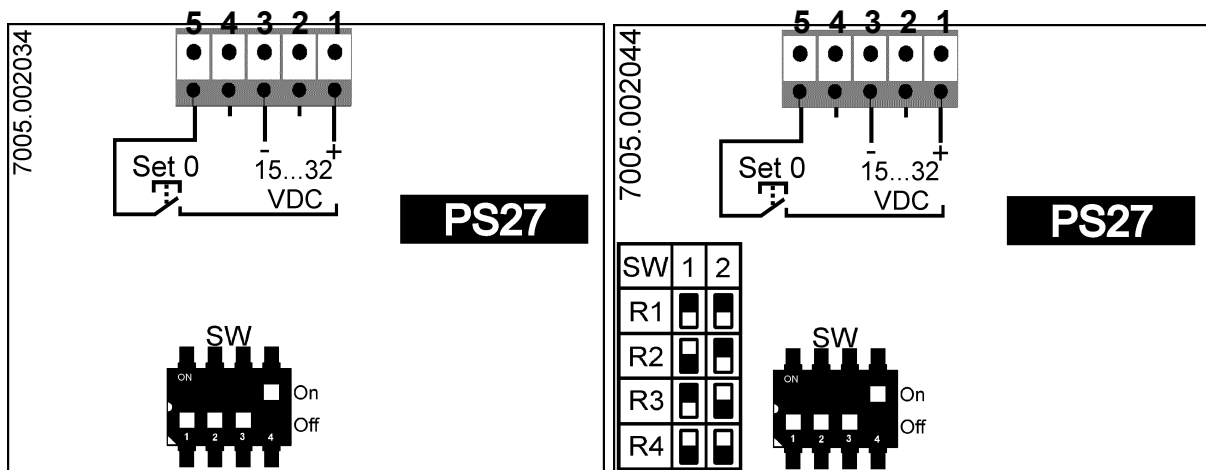

One measurement range

Four measurement ranges

ST4 Pin	Connection name	Meaning
1	24V	+terminal 15-32VDC
2	GND	Not used
3	OUT	-terminal
4	GND	Not used
5	SET 0	Zero-point input

3.4 Connections M12-plug

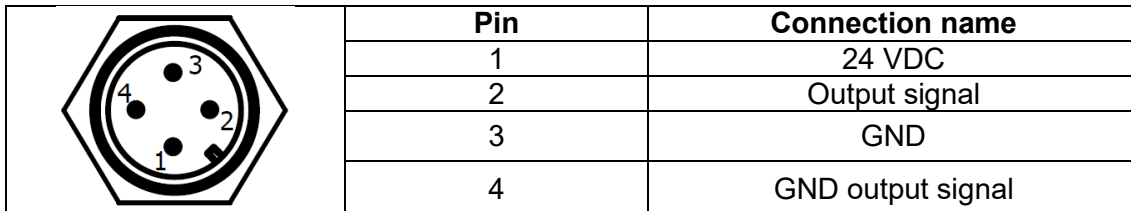

4. Resetting Offset

i After starting the pressure transmitter, give it some 15 minutes to warm up. During this time the output signal may be unstable.

Zero-point calibration of the appliance is only effected via the input assigned for this purpose. **The user must ensure that the appliance is not subjected to any pressure during the calibration process as this might lead to a wrong offset value which, in turn, would result in a wrong output signal.** The 24V input makes it possible to activate a 3/2 directional control valve with the same signal, which switches the PS27's pressure inputs at zero pressure during the zero calibration process. In this case the zero point calibration signal must be applied until there is no doubt that the pressure has fallen to zero.



While Resetting Offset is in progress, the power supply must not be switched off. This might result in a loss of the device setting and may leave the PS27 unusable.

5. Configuring the Output Signal

The user can configure the PS27's output signal. This can be done in various ways

Output	SW Pos 3	SW Pos 4	Comments
0...10V	on	off	$R_{Load} > 50k \Omega$
2...10V	on	on	$R_{Load} > 50k \Omega$
0...20mA	off	off	max. load 500 Ω
4...20mA	off	on	max. load 500 Ω

The two-wire model must be configured by the manufacturer.

6. Setting the Measuring Range (Optional)

The transmitter with 4 measuring ranges can be adapted to the measuring assignment in question. The teaching of 4 measuring ranges into the appliance has been undertaken by the manufacturer. The switches 1 and 2 of SW can be used to select the measuring range in question before the transmitter is switched on.

SW Pos 1	SW Pos 2	Measuring range
off	off	1
on	off	2
off	on	3
on	on	4

The limiting values of the measuring ranges are noted on the nameplate of the PS27. Display-optional appliances indicate the limiting value of the selected measuring range for 1.5 seconds after being switched-on. The appliance should be re-zeroed following any measuring range change-over. This is because the amplification change-over may produce offset voltages.

Four-wire:

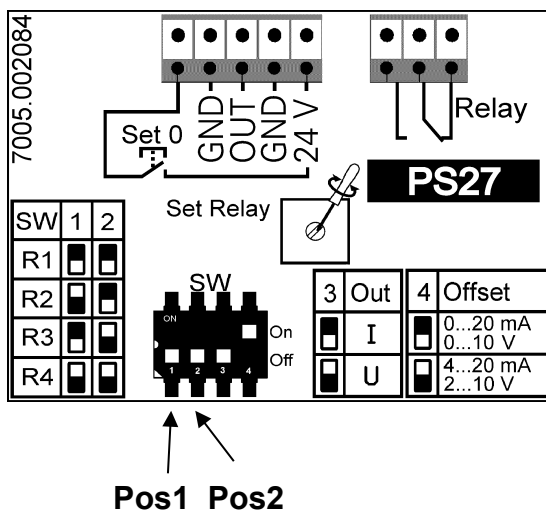

Two-wire:

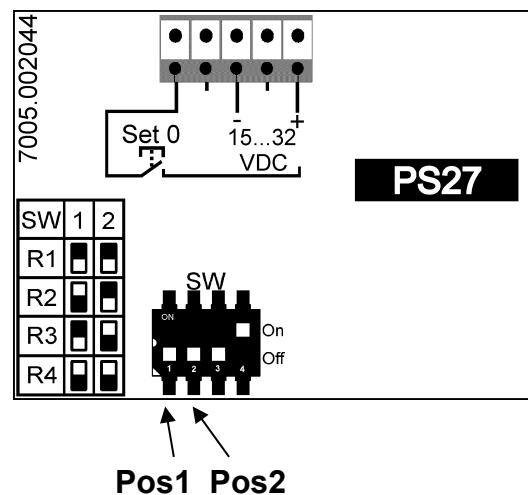

7. Display (Option)

To show up the readings, the PS27 can also be fitted out with a display. The readings will be shown in either Pa or kPa depending on the limiting value of the measuring range. The number of the measuring range selected is always shown on the bottom line of the display.

On switching on a display-equipped appliance, the first thing shown is the PS27 programme version followed by a 1.5 second screening of the limiting value of the selected measuring range and then the actual readings.

8. Setting the Relay Operating Point (Option)

The relay operating point can be adjusted with the aid of the potentiometer P2.1 (Set Relay). Adjustment is easiest when the desired switching pressure is applied and the potentiometer set so that the relay is just triggered.

Please note: The relay is connected to the sensor's output so that any adjusted time delay will also cause a delay in relay triggering.

9. In case of Malfunctions

Fault description	Possible cause	Corrective action
No output signal	<ul style="list-style-type: none"> • Supply voltage is not connected • Incorrect supply voltage connected • Defective input protection diode Only for DC power: <ul style="list-style-type: none"> • defective reverse polarity diode 	<ul style="list-style-type: none"> • Connect correct supply voltage • Connect correct supply voltage (see rating plate) • Send the appliance to the manufacturer for repairs • Send the appliance to the manufacturer for repairs
Output signal is constant despite change in pressure	<ul style="list-style-type: none"> • Defective output protection diode • Pressure ports reversed 	<ul style="list-style-type: none"> • Send the appliance to the manufacturer for repairs • Connect the pressure as described in "3. Startup"
Output signal incorrect	<ul style="list-style-type: none"> • Faulty pressure sensor • Zeroing with pressure applied For current output: <ul style="list-style-type: none"> • load too high For voltage output <ul style="list-style-type: none"> • Load resistance too low 	<ul style="list-style-type: none"> • Send the appliance to the manufacturer for repairs • Renewed zeroing without pressure • Note maximum 500 Ω load • Note minimum 50 k load resistance Ω (see "10 Specifications")

10. Specifications

Measurement accuracy:	± 2 % of the set value for ≥ 100 Pa ± 3 % of the set value for < 100 Pa
Temp. coefficient zero point:	± 0.1 % FS / K
Temp. coefficient span:	± 0.1 % FS / K
Measurement ranges:	50 / 100 / 200 / 500 Pa 1 / 2 / 5 / 10 kPa
	As an option, the customer can use a DIP-switch to select 4 pre-set measuring ranges
Step response time (T63): (Time constant)	20 ms...4s (adjustable factory provided)
Pressure ports:	hose connector nominal 4 or 6 mm width Push-in fitting 4 or 6mm
Output signals:	0/2...10 V ($R_L > 50 \text{ k}\Omega$) 0/4...20 mA ($R_L \leq 500\Omega$) 4...20 mA (two-wire 17...32 V, $R_L \leq 500\Omega$)
Switching contact (optional):	max. 230 VAC, 6 A; min. 500 mW
Display (optional):	3½-digit LCD
Overpressure limit:	Range < 2 kPa : 50 kPa Range > 10 kPa : 200 kPa
Storage temperature:	-20°C...+70°C
Rated temperature range:	-20°C...+60°C, with Display 0°C...50°C
Supply voltage:	24 VDC/VAC ±10 % (no galvanic isolation) 15 ... 32 VDC (two-wire) (no relay output)
Power consumption:	approx. 1VA
Operating position:	vertical preference
Housing:	see drawing
Protection class:	IP 65
Installation:	The appliance can be installed either on a top-hat rail or on a wall with fastening holes
Certificates:	CE / UKCA

11. Dimensional Drawing

no LCD

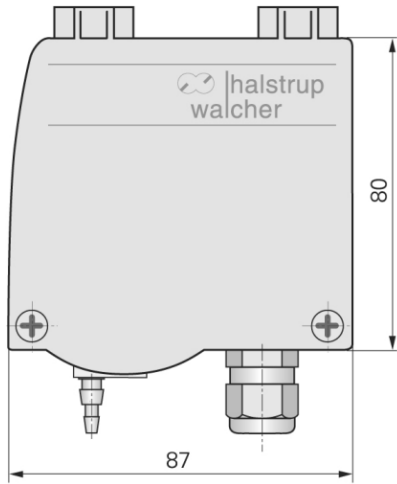

with LCD

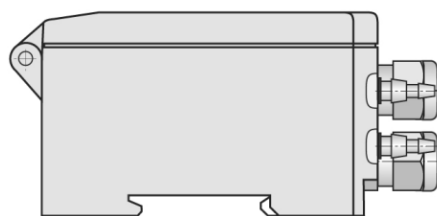
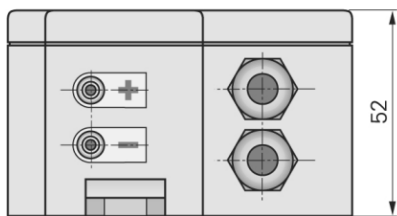
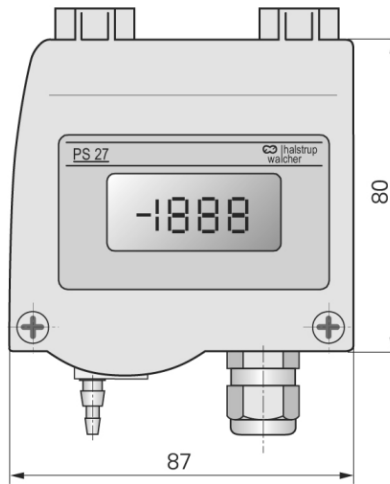

A combination of different pressure and electrical connections can be freely selected at the time of purchase.

The following variants are available for the pressure connection:

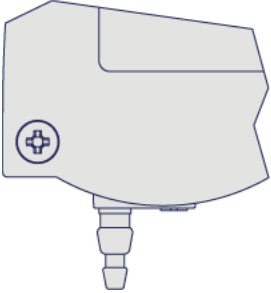
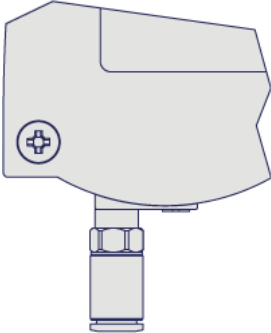
hose connector 4 oder 6 mm	Push-in fitting 4 oder 6mm
	

The following variants are available for the electrical connection:

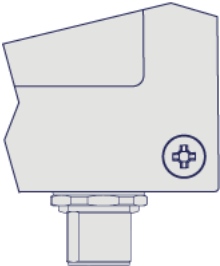
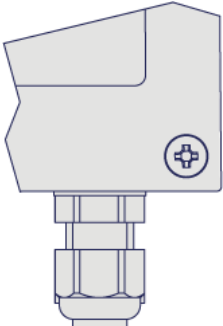
M12 plug 4polig, A-kodiert	cable gland M16
	

For more information on our measurement technology products, please visit our homepage at: www.halstrup-walcher.de/en/products/measurement-technology/



12. Certificates of Conformity

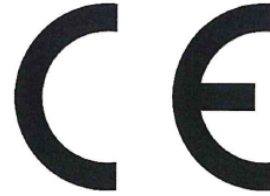

EU-Konformitätserklärung EU Declaration of Conformity

Company	halstrup-walcher GmbH, Stegener Str. 10, 79199 Kirchzarten erklärt als Hersteller in alleiniger Verantwortung, dass das Produkt declares as manufacturer under sole responsibility, that the product
Product	Differenzdruck-Messumformer PS27 Differential Pressure Transmitter
Regulations	den folgenden Europäischen Richtlinien entspricht: conforms to following European Directives: LVD 2014/35/EU EMC 2014/30/EU RoHS 2011/65/EU
Standards	angewandte harmonisierte Normen: applied harmonized standards: EN 61010-1:2010 +A1:2019 EN IEC 61000-6-2:2019 EN IEC 63000:2018
Declaration	EU Konformitätserklärung ausgestellt von EC Type Examination Certificate issued by



Geschäftsführer

Managing Director

Kirchzarten, 17. Nov. 2022



UK Declaration of Conformity

Company halstrup-walcher GmbH, Stegener Str. 10, 79199 Kirchzarten
declares as manufacturer under sole responsibility, that the product

Product Differential pressure transmitter type
PS27

Regulations is in conformity with relevant statutory requirements:

EMC Electromagnetic Compatibility Regulations 2016 No. 1091
RoHS RoHS Regulations 2012 No. 3032

Standards applied standards:
EN 61010-1:2010
EN 61000-6-2:2005
EN IEC 63000:2018

Declaration signed for and on behalf of

Managing Director
Kirchzarten, 26. Jan.2022